

City of Tomah

Mailbox Replacement Policy

The City of Tomah Public Works Department has many operations that require various types of vehicles and equipment to work along the street gutter and curb line. These operations include snow removal and plowing, mechanical sweeping, brush and leaf pickup. Performing these operations require the Street Department to plow or clean as close to the curb as possible. The Street Department takes great care not to damage any property within the city right-of-way: however mailboxes do occasionally get damaged.

In the majority of cases, the City had repaired or replaced all mailboxes that residents claimed were damaged by its various operations. Due to the time and costs associated with these repairs and replacements, we have established a new policy for mailbox repairs and new mailbox installation.

The Policy

The City of Tomah Public Works Department will no longer repair or replace damaged mailboxes or support posts. Instead, when the following two (2) criteria are met, it will provide reimbursement up to a maximum of \$50.00 (copies of receipts are needed):

1. It is determined that the City Operator damaged the mailbox while operating within the street gutter and curb line: and
2. The mailbox had been properly installed (e.g., meeting USPS installation guidelines discussed below) and maintained prior to the damage occurring.

If both criteria noted above are met, you may repair or replace the mailbox/post at your own cost. The City of Tomah will then reimburse you up to a maximum of \$50.00 (copies of receipts are needed). The Public Works Department will no longer repair or replace damaged mailboxes or support posts.

Note: Any mailbox damaged by the weight of the plow windrow (snow exiting the end of the plow) will no longer be covered under this policy and no reimbursement will be offered.

Guidelines established per USPS regulations regarding mailbox installation:

- Mailboxes installed on the streets with a curb must be 41" to 45" above the street surface.
- The face of the mailbox must be between 6" and 8" back from the curb face (see diagram).

Mailbox Location (POM 632)

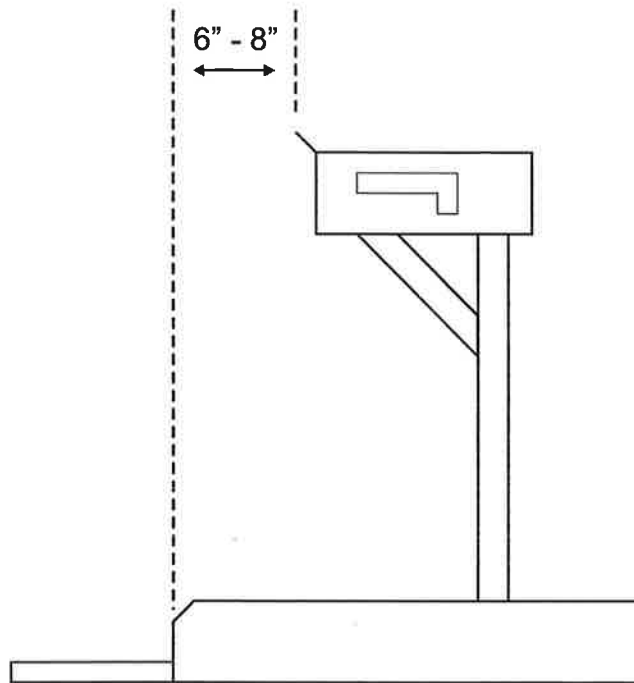

Mailboxes are set back 6" - 8" from the front face of the curb or road edge to the mailbox door.

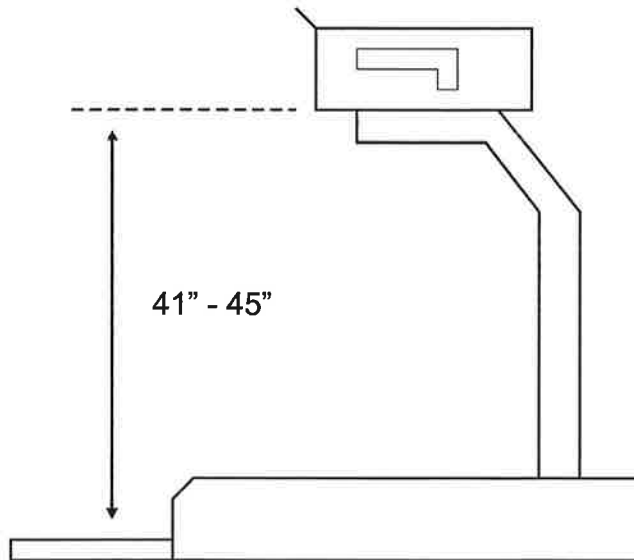

Generally, mailboxes are installed at a height of 41" - 45" from the road surface to the bottom of the mailbox.

The mailbox should ideally be located to the right of the driveway. This allows your letter carrier to serve your mailbox without blocking your driveway.

Note: Check with your local municipality/county for mailbox requirements which may differ from above. Customers should contact the postmaster or carrier before erecting or replacing their mailbox.